

10K SERIES HORIZONTAL CENTRIFUGAL CASTING MACHINES



Equipment Capacity

Total Load Rating:

10,000 lbs Mold & Casting
(4535 kgs)

Max. Casting Diameter:

18" (457 mm) O.D.

Min. Casting Diameter:

3" (76 mm) O.D.

Max. Mold Length:

18 Feet (5.4 M)

Centrifugal Casting Machines for the Foundry Industry

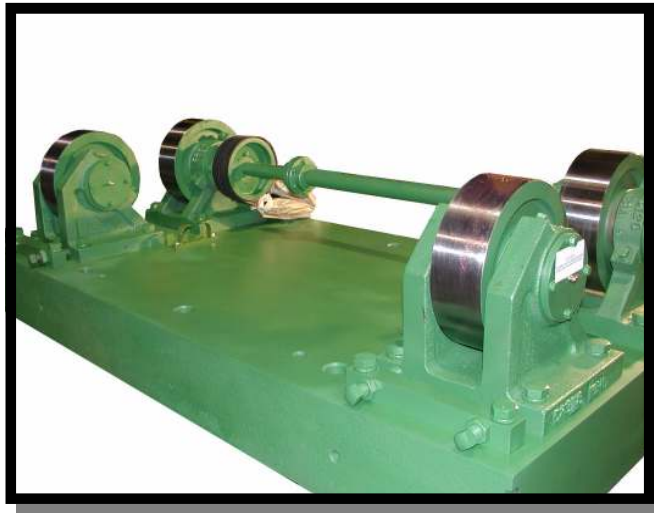

Types of castings that can be produced:

- Furnace Rolls
- Forming Rolls
- Extrusion Billets
- Ship shaft liners
- Bi-Metal Rolls
- Alloy Tubes
- Reformer Tubes
- Bushing Stock

Standard Equipment specifications

- Spinner Base Assembly
- Mold Cooling Assembly
- Runner Pot
- Operators Controls
- Protective Water Guard
- Mold Heating Assembly
- Variable Speed Drive Unit
- Spray System

TULSA CENTRIFUGAL CASTING MACHINES

P.O. Box 702751, Tulsa, OK 74170-2751

Phone: **918-585-1400** Fax: 918-779-6085
Email: sales@centrifugalcasting.com
Web: www.centrifugalcasting.com

Typical Equipment Layout for 10K Series

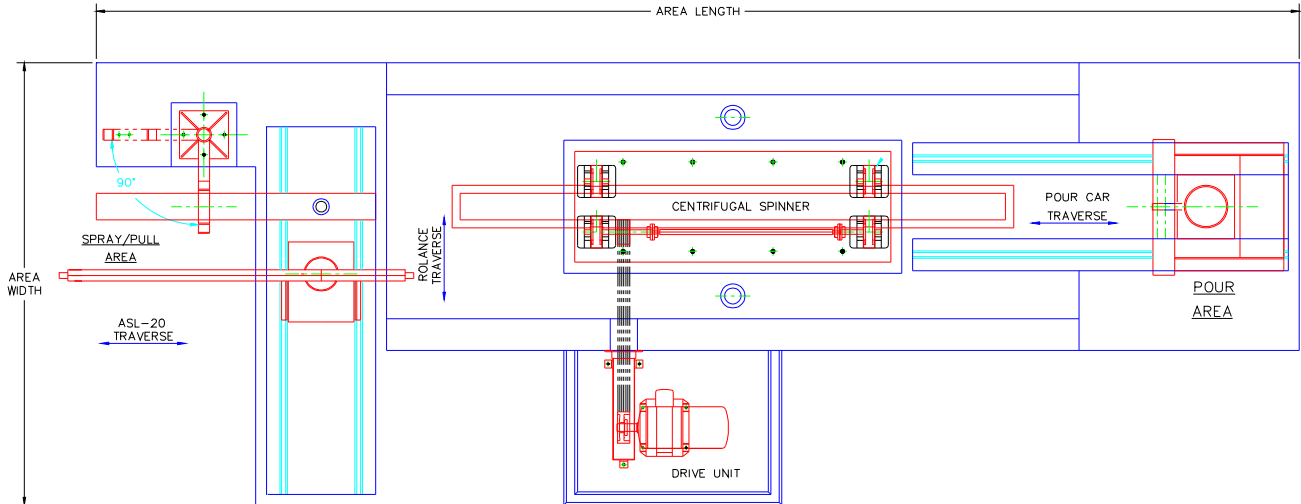
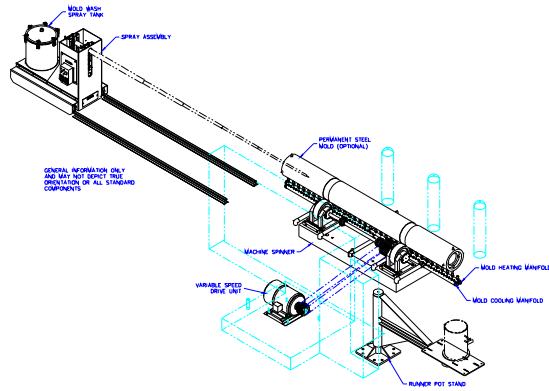

Mold Length	Area Width	Area Length	Floor Space	80 psi Air CFM	40 psi Water GPM	0.4 psi GAS CFM
4 Ft. (1.2M)	12 Ft (3.7M)	25 Ft (7.6M)	300 Sq. Ft.	40	120	2.6
6 Ft. (1.8M)	12 Ft (3.7M)	29 Ft (8.8M)	348 Sq. Ft.	40	180	4
8 Ft. (2.4M)	12 Ft (3.7M)	33 Ft (10M)	396 Sq. Ft.	40	240	5.5
12 Ft. (3.7M)	12 Ft (3.7M)	41 Ft (12.5M)	492 Sq. Ft.	40	360	8
14 Ft. (4.2M)	12 Ft (3.7M)	45 Ft (13.7M)	540 Sq. Ft.	40	420	9.4
18 Ft. (5.5M)	12 Ft (3.7M)	57 Ft (17.4M)	684 Sq. Ft.	40	600	13.4

TULSA CENTRIFUGAL CASTING MACHINES