



VP1200 VERTICAL CENTRIFUGAL CASTING MACHINE

Model VP-1200 Vertical Portable Centrifugal Casting Machine for the production of ferrous or non-ferrous castings.

Capable of spinning up to 60 G force on the metal being cast.

Standard Features:

5 HP Variable Speed

Drive

Mold Water Cooling

Mold Heater

Pouring Funnel

30" Adapter Table

Operators Controls

Mold Wash Spray Gun



Maximum Table Diameter: 30" (762 mm)

Maximum Mold Height: 18" (457 mm)

Balanced load at usual top speed 685 rpm: 1200 lbs (Mold & Casting)

The combined unique equipment design and variable speed drive unit makes the VP series of Vertical Centrifugal Casting machines the most versatile machine for the production of all types of ferrous and non ferrous castings using the "Centrifugal Casting" process.

True Centrifugal, Semi-Centrifugal, and Centrifuged parts can be produced. No special skills required. Tulsa Centrifugal Casting Machines provides all the necessary foundation and utility drawings, operators manual, and a current copy of the centrifugal manual making the "VP" series the most economical on the market.

Tulsa Centrifugal Casting Machines, LLC
Main Office: 918-585-1400 Fax: 918-779-6085
Email: sales@centrifugalcasting.com
Web: www.centrifugalcasting.com

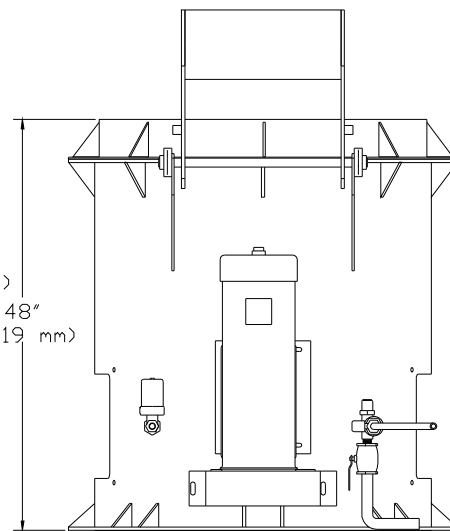
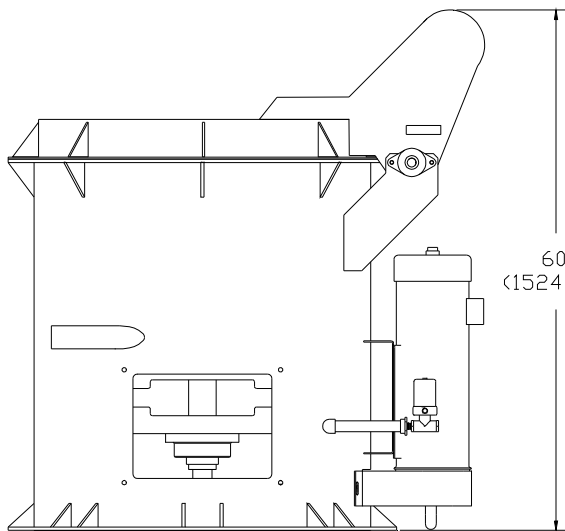
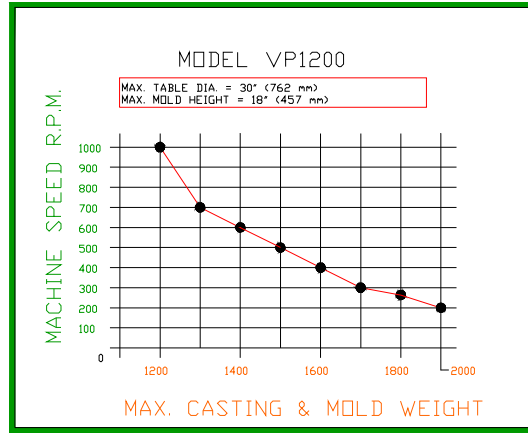
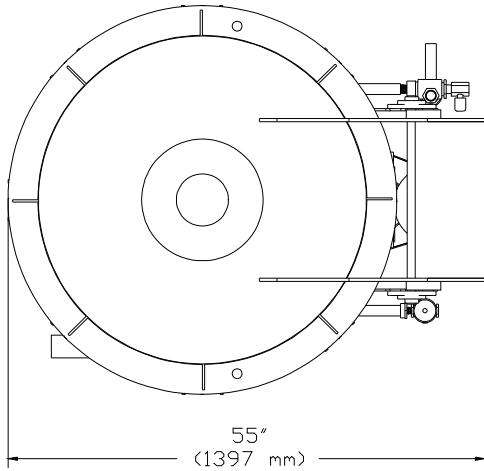

Tulsa Centrifugal Casting Machines, LLC
Main Office: 918-585-1400 Fax: 918-779-6085
Email: sales@centrifugalcasting.com
Web: www.centrifugalcasting.com